

RICOH PRIPORT VT 2105

SERVICE MANUAL

SECTION 1

OVERALL MACHINE INFORMATION

1. SPECIFICATIONS

Configuration:	Desktop	
Master processing:	Digital	
Printing process:	Full automatic one drum stencil system	
Original type:	Sheet	
Original size:	Maximum 307 mm x 432 mm (12.0" x 17.0") Minimum 90 mm x 140 mm (3.6" x 5.5")	
Reproduction ratios:	LT Version	A4 Version
	Full Size	100%
	Reduction	100%
		93%
		75%
		82%
		64%
		71%
Image mode:	Line/Photo	
Color printing:	Drum Unit replacement system	
Master feed/eject:	Roll master automatic feed/eject	
Printing area:	Maximum: 250 mm x 355 mm (9.8" x 13.9") at 20°C/ 65 % RH.	
Leading edge margin:	5 ± 3 mm at "0" position	
Print paper size:	Minimum: 90 mm x 148 mm (3.6" x 5.8") Maximum: 325 mm x 447 mm (12.8" x 17.6")	
Print paper weight:	50 g/m ² to 215 g/m ²	
Printing speed:	60, 75, 90, 105, 120 sheets/minute (5 steps)	
First print time:	42 ± 3 seconds (B4 size)	
Paper feed table capacity:	1000 sheets (66.3 g/m ² / 17.6 lb)	
Paper delivery table capacity:	500 sheets (66.3 g/m ² / 17.6 lb)	
Power source:	120 V, 60 Hz	3.0 A
	220/240 V, 50/60 Hz	1.8 A

Maximum Power consumption:	120 V version: 300 W 220/240 V version: 300 W
Weight:	120 V version: 99 kg (217.8 lb) 220/240 V version: 104 kg (228.8 lb)
Dimensions: (W x D x H)	Stored: 735 mm x 607 mm x 577 mm (29.0" x 23.9" x 22.8") Set up: 1279 mm x 607 mm x 656 mm (50.4" x 23.9" x 25.9")
ADF original capacity:	20 sheets (66 g/m ²) or 1.8 mm height
Original guide width settings:	98 mm to 316 mm (38.6" to 12.44")
Original scanning time:	5 ms/1 line
Original thickness:	0.05 mm to 0.8 mm
Original feed speed:	16.9 mm/second (When master processing) 33.9 mm/second (When not master processing)
Pixel density:	300 dots/inch
Master eject box capacity:	30 masters (Normal condition) 25 masters (10°C/30% RH Condition)
Paper feeding:	Friction roller/center separation system
Feed table side plate width settings:	88 mm to 330 mm (3.46" to 12.99")
Paper feed roller pressure:	Normal position 250 g Thick paper position 550 g
Separation roller pressure:	Normal position 180 g Weak position 70 g
Side registration:	± 10 mm (manual)
Vertical registration:	± 20 mm (mechanical)
Ink supply:	Automatic ink supply system
Press roller pressure:	10 ± 0.3 kg
Paper delivery:	Air knife/vacuum delivery
Delivery side plate width settings:	90 mm to 320 mm (3.54" to 12.6")
Print counter:	7 digits
Master counter:	6 digits

Supplies:

Priport
Master VT- II - M:
(300 dots/inch)

Thermal master 280 mm width

Master roll 250 masters/1 roll
Roll diameter 130 mm
Master length 480 mm/1 master
Max run length 2000 prints

Ink colors:
(500 cc/pack)

Black, Red, Blue, Green, Brown

2. DIFFERENCE BETWEEN VT2000 SERIES AND VT2105

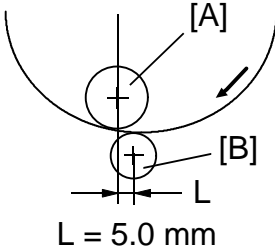
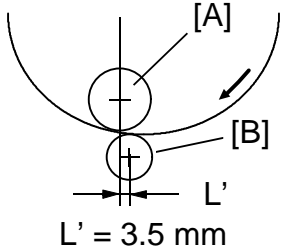
No.	Item	Remarks								
1.	CCD	<p>The pixel density of the VT2105 is 300 dots/inch. Corresponding to this, the CCD used on the VT2105 is the same as the one used on the SS800 series.</p> <table border="1" data-bbox="525 439 1011 586"> <tr> <td>Number of effective Pixels:</td> <td>3648pixels</td> </tr> <tr> <td>Reading Length:</td> <td>309 mm</td> </tr> <tr> <td>Photo Signal Storage:</td> <td>5 ms</td> </tr> </table>	Number of effective Pixels:	3648pixels	Reading Length:	309 mm	Photo Signal Storage:	5 ms		
Number of effective Pixels:	3648pixels									
Reading Length:	309 mm									
Photo Signal Storage:	5 ms									
2.	Thermal Head	<p>Due to pixel density change, the thermal head has been changed.</p> <table border="1" data-bbox="540 729 976 940"> <tr> <td>Density of thermal heating elements</td> <td>300 dots/inch</td> </tr> <tr> <td>Number of thermal heating elements</td> <td>3072 dots</td> </tr> <tr> <td>Memory length</td> <td>256 mm</td> </tr> <tr> <td>Applied voltage</td> <td>19~24 V</td> </tr> </table>	Density of thermal heating elements	300 dots/inch	Number of thermal heating elements	3072 dots	Memory length	256 mm	Applied voltage	19~24 V
Density of thermal heating elements	300 dots/inch									
Number of thermal heating elements	3072 dots									
Memory length	256 mm									
Applied voltage	19~24 V									
3.	Drum Ink Roller Layout	<p>To ensure paper separation from the drum, the ink roller has been shifted forward the paper feed table. The distance L has been changed from 5.0 mm to 3.5 mm.</p> <div style="display: flex; justify-content: space-around; align-items: center;"> <div style="text-align: center;"> <p>VT2100 series</p>  <p>L = 5.0 mm</p> </div> <div style="font-size: 2em; margin: 0 20px;">→</div> <div style="text-align: center;"> <p>VT2105</p>  <p>L' = 3.5 mm</p> </div> </div> <p>NOTE: The optional color drum for the VT2105 is commonly used for the VT2100 series. (The distance L of the color drum is 4.5 mm)</p>								

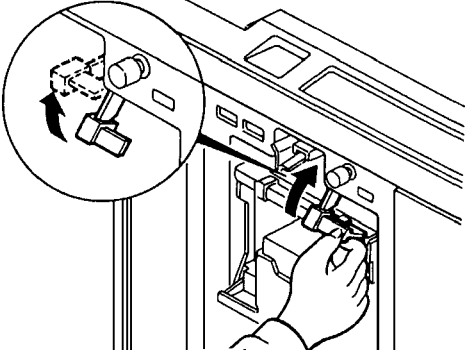
4.	Drum Connector	<p>To ensure drum connection, a drum lock lever is added inside the front door. To remove the drum from the machine, the drum release lever must be pulled up to disconnect the drum connector.</p> 
5.	Ink Detection Board	<p>The location of the ink detection board has been changed from the upper side to the right side of the drum shaft. The ink type switch (SW901), which was not used (always set at oil type), has been removed.</p>
6.	Drum Shaft	<p>To supply ink to the ink roller evenly, the second ink supply hole (count from the front side) of the drum shaft is covered with a strip of tape.</p>
7.	Exit Pawl Air Pump	<p>To ensure paper separation from the drum, the exit pawl air pump system is standardized. (The pump system can optionally be installed on the VT2000 series.)</p>
8.	Thermal Head Drive	<p>The thermal head drive board has been removed. The function of the board has been moved to the image processing board and the main board.</p> <p>The thermal head voltage is directly applied from the power supply unit. The main board applies signal to the PSU to supply thermal head voltage only during the master making process.</p>

3. ELECTRICAL COMPONENT DESCRIPTIONS

INDEX No.	NAME	FUNCTION
Motors		
4	Original Transport Motor	Transports the original to the scanner section.
10	Master Feed Motor	Feeds the master to the drum.
11	Cutter Motor	Cuts the master.
14	Master Eject Motor	Sends used master into the master eject box.
18	ADF Drive Motor	Feeds the original to the scanner section.
25	Image Shift Motor	Changes the timing between the paper feed roller and the drum to adjust the vertical image position.
28	Paper Table Drive Motor	Raises and lowers the paper table.
30	Main Motor	Drives paper feed, drum, printing and paper delivery unit components.
60	Air Knife Motor	Rotates the fan to separate the paper leading edge from the drum.
61	Vacuum Motor	Provides suction so paper is held firmly on the transport belt.
Solenoids		
3	Original Pressure Solenoid	Presses the original pressure plate down on the originals.
15	Master Eject Solenoid	Moves the master eject roller to contact the drum surface.
21	Master Eject Clamper Solenoid	Opens the master clamp to eject the master.
22	Drum Lock Solenoid	Prevents removal of the drum unit unless the drum is at the original stop position
23	Master Feed Clamper Solenoid	Opens the master clamp to clamp the master.
24	Reverse Roller Solenoid	Releases the clutch to rotate the reverse roller.
27	Paper Feed Solenoid	Releases the paper feed sector gear to rotate the paper feed roller.
32	Printing Pressure Solenoid	Moves the press roller against the drum.
47	Ink Supply Solenoid	Releases the spring clutch to activate the ink supply pump.
Switches		
6	Right Cutter Switch	Detects when the cutter position is at the far right.
12	Left Cutter Switch	Detects when the cutter position is at the far left.
16	Master Box Switch	Checks whether the master eject box is installed correctly or not.
36	Master Eject Unit Safety Switch	Checks whether the Master Eject Unit is closed correctly or not.

INDEX No.	NAME	FUNCTION
41	Master Cut Switch	Informs the CPU to cut the master paper leading edge.
42	Scanner Safety Switch	Checks whether the scanner unit is closed correctly or not.
44	Drum Rotation Switch	Informs the CPU to rotate the main motor at 10 rpm.
45	Front Door Safety Switch	Checks whether the Front Door is set correctly or not.
46	Drum Safety Switch	Checks whether the drum unit is set correctly or not.
52	Paper Table Safety Switch	Checks whether the paper table is opened correctly or not.
57	Interlock Switch	Releases the cover safety functions.
59	Main Switch	Turns the power on or off.
62	Full Master Detecting Switch	Informs the CPU when the master eject box is full of masters.
63	Pressure Plate Position Switch	Informs the CPU when the pressure plate has reached the home position.
64	Printing Density Switch	Use to select the printing density according to the type and quality of the original.
65	ADF Safety Switch	Check whether the ADF unit is set correctly or not.
Sensors		
1	Original Registration Sensor	Informs the CPU when the original leading edge reaches the exposure glass.
2	2nd Original Sensor	Detects when the original is set.
9	Master End Sensor	Informs the CPU when the plotter unit runs out of master roll.
13	Master Buckle Sensor	Detects master buckles.
17	Master Eject Sensor	Detects when the used master is sent into the master eject box.
19	1st Original Sensor	Detects when the original is set in the ADF mode.
29	Drum Rotation Sensor	Supplies timing pulses to the main board.
33	2nd Drum Position Sensor	Checks the position of the drum.
34	1st Paper Exit Sensor	Detects misfeed.
35	2nd Paper Exit Sensor	Detects misfeed.
37	1st Drum Position Sensor	Checks the position of the drum.
49	Paper Table Height Sensor	Detects when the paper table reaches the paper feed position.
51	Paper End Sensor	Informs the CPU when the paper table runs out of paper.
53	Paper Table Lower Limit Sensor	Detects when the paper table reaches the lowest position.
54	Printing Pressure Sensor	Informs the CPU when the printing pressure is applied.

INDEX No.	NAME	FUNCTION
Printed Circuit Board		
7	Power Supply PCB	Rectifies 100V AC input and supplies DC voltage.
31	AC Drive PCB	Controls the AC component by relays.
38	Ink Detection PCB	Control the ink supply.
39	CCD PCB	Converts the light intensity into the electrical signal.
40	A/D Conversion PCB	Converts the analogue signal into the digital signal.
43	Operation Panel	Controls the LED performance and monitors the key operation.
48	Main Control PCB	Controls all machine functions both directly and through other boards.
50	Image Processing PCB	Controls the master processing performance.
Counters		
55	Copy Counter	Keeps track of the total number of copies made.
56	Master Counter	Keeps track of the total number of masters made.
Others		
5	Fluorescent Lamp Stabilizer	Stabilizes the power supplement to the fluorescent lamp.
8	Thermal Head	Burns the image on to the master.
20	Fluorescent Lamp	Exposes the original.
26	Encoder	Converts 16 image positions to 4 bit data.
58	Circuit Breaker	Cuts the ac line.

SECTION 2

DETAILED SECTION DESCRIPTION

1. OPTICS

1.1 OVERALL

The CCD [A] used on the VT2105 is commonly used on the SS800 series. Due to the pixel density difference between the VT2105 and SS800 series (300 dots/inch and 12 dots/mm), the reduction ratio (lens [B] position) of the VT2105 is different from the SS800 series.

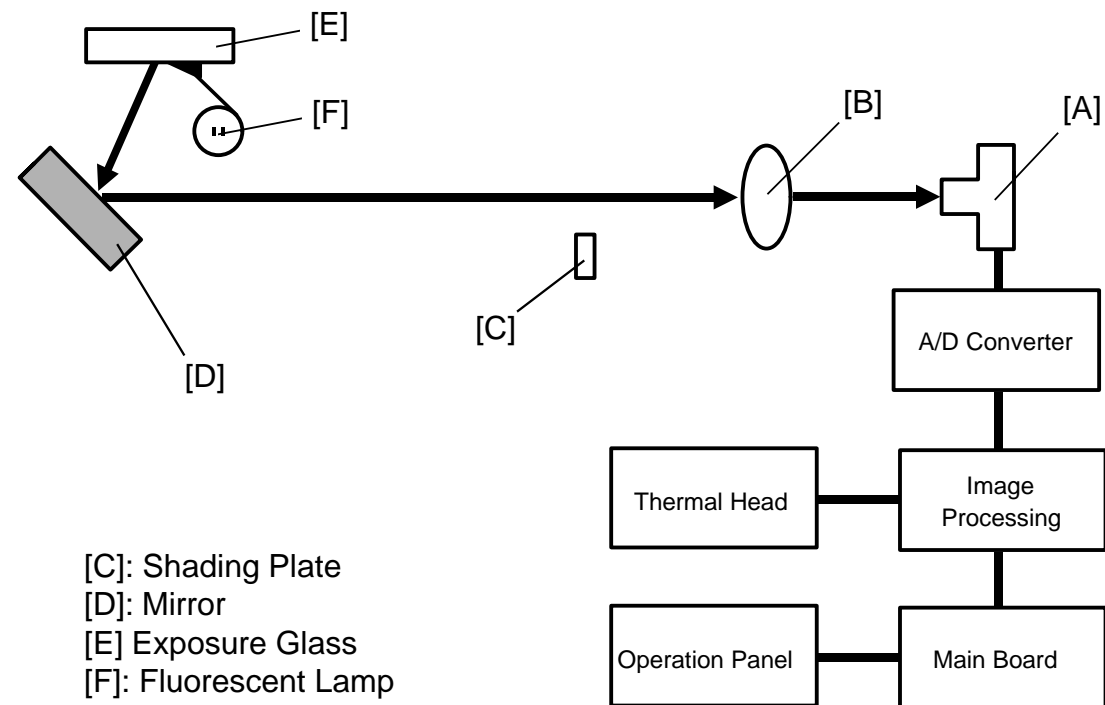

The thermal head drive board has been removed. The function of this board has been moved to the image processing board and the main board.

1.2 CIRCUIT

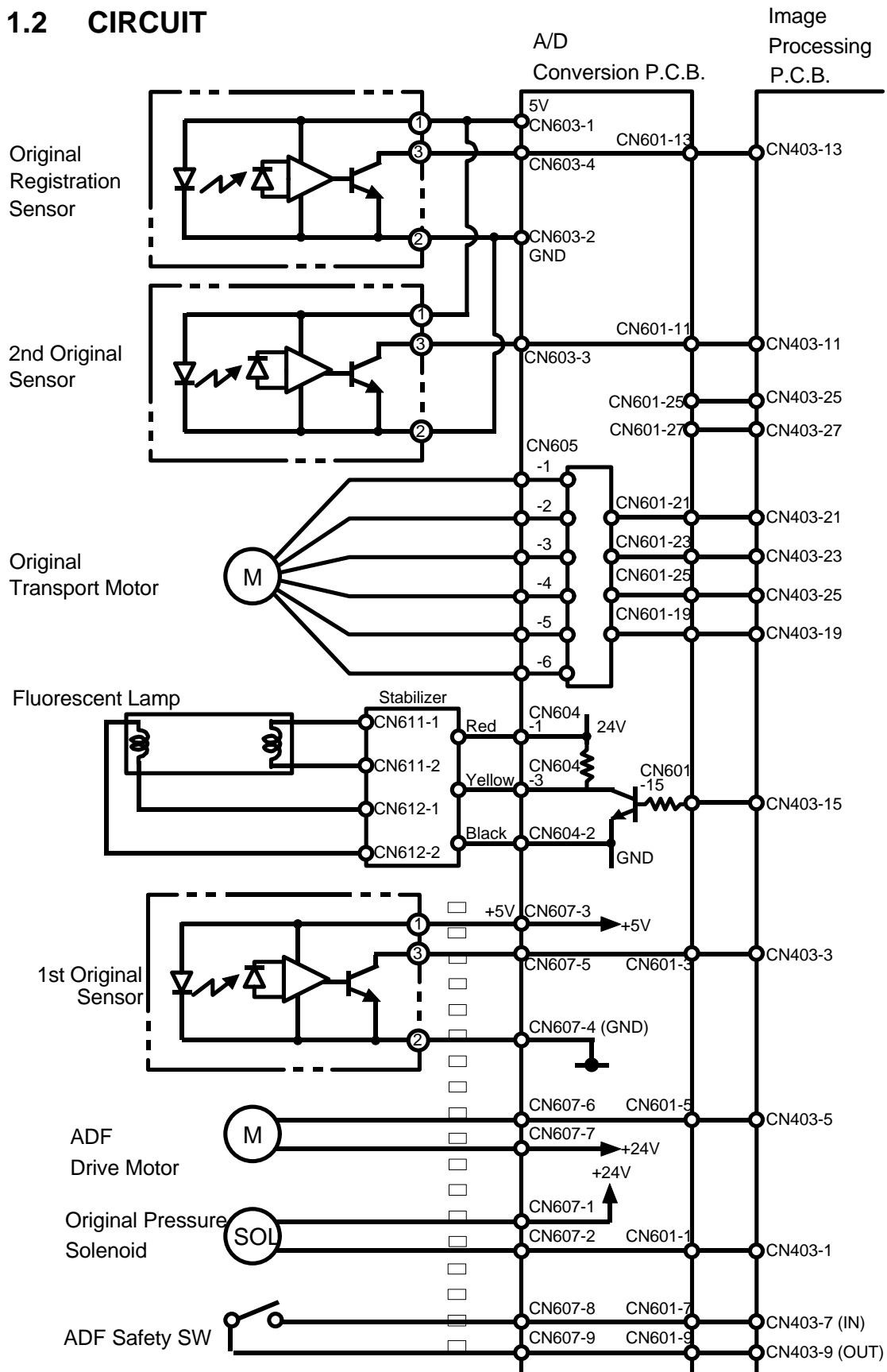

Component Name	I/O	ID Conversion Board		Description
		CN No		
Fluorescent Lamp	O	604-3	$\overline{24V}$ \downarrow $0V$	When the fluorescent lamp turns ON, the CN604-3 goes to 0V.
ADF Drive Motor	O	607-6	$\overline{24V}$ \downarrow $0V$	When the ADF drive motor starts rotating CN607-6 goes to 0V.
Original Pressure Solenoid	O	607-2	$\overline{24V}$ \downarrow $0V$	When the original pressure solenoid is energized, CN607-2 goes to 0V.
Original Registration Sensor	I	603-4	$\overline{24V}$ \downarrow $0V$	When the original registration sensor is activated, CN603-4 goes to 0V.
2nd Original Sensor	I	603-3	$\overline{24V}$ \downarrow $0V$	When the 2nd original sensor is activated, CN603-3 goes to 0V.
1st Original Sensor	I	607-5	$\overline{24V}$ \downarrow $0V$	When the 1st original sensor is activated, CN607-5 goes to 0V.

Detailed Descriptions

1.3 THERMAL HEAD

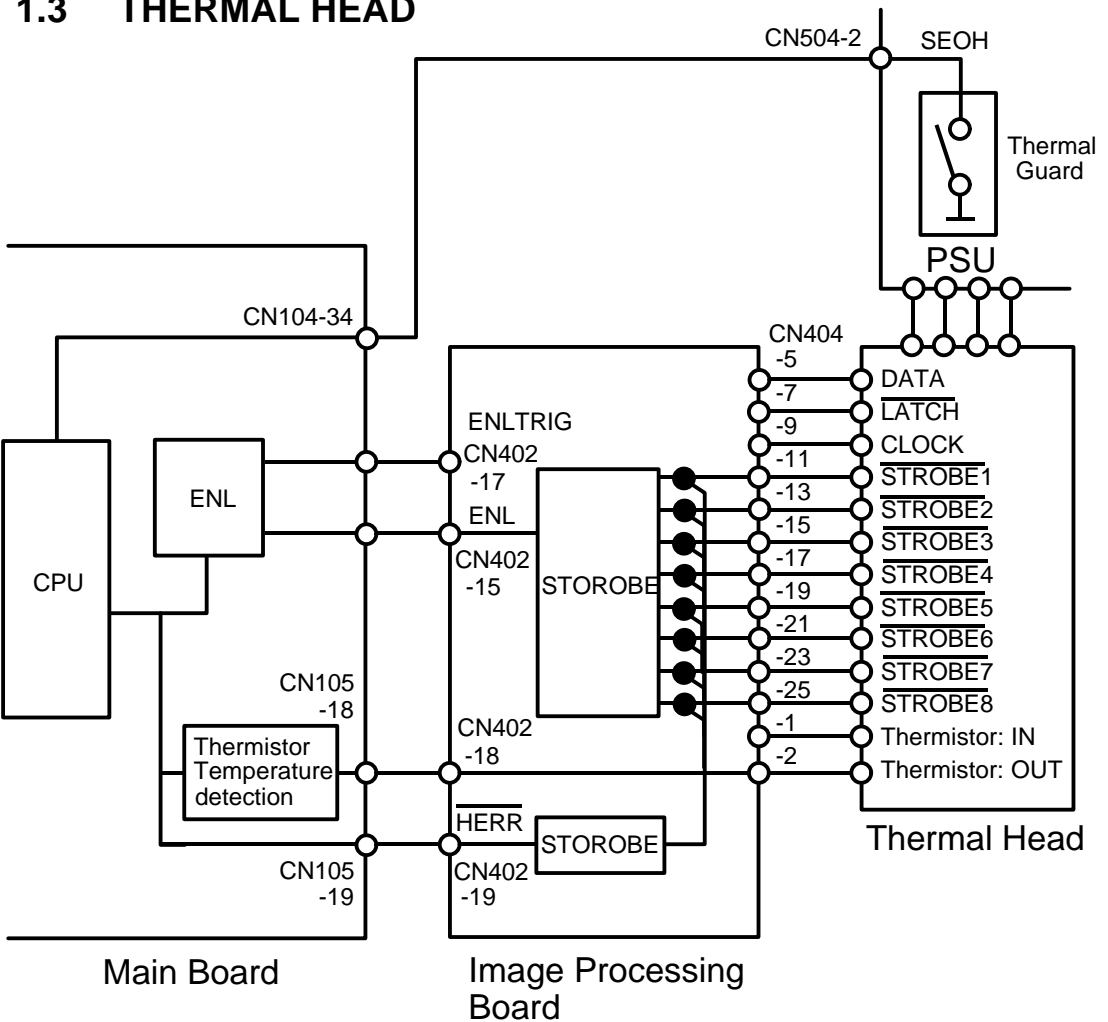

(1) Specification

The VT2105 uses a 300 DPI thermal head.

Thermal head

- Memory length 256 mm
- Number of thermal head elements 3072 dots
- Density of thermal head elements 300 DPI
- Applied voltage 19~24 V

(2) Thermal Head Control

The thermal head drive board has been removed. The function of this board has been moved to the image processing board and the main board.

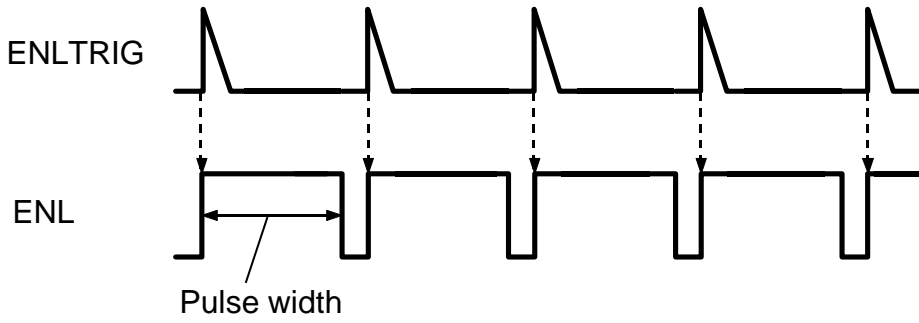

The thermal head energy is controlled by changing pulse width. The pulse is controlled by the ENL signal from the main board corresponding to ENLTRIG from the image processing board.

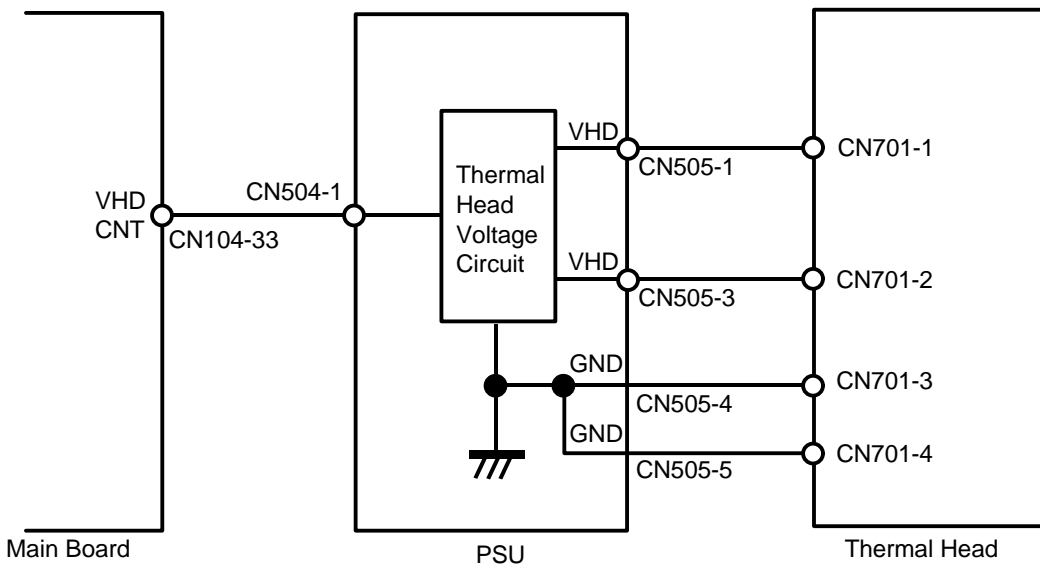

Thermal head voltage (VHD: 19V~24V) is applied from PSU only during the master making process. This is controlled by the VHDCNT signal (CN104-33) from the main board.

VHDCNT	(CN104-33)	VHD	(CN505-1) (CN505-3)
	0 V		19~24 V
	5 V		0 V

2. DRUM

2.1 DRUM CONNECTION MECHANISM

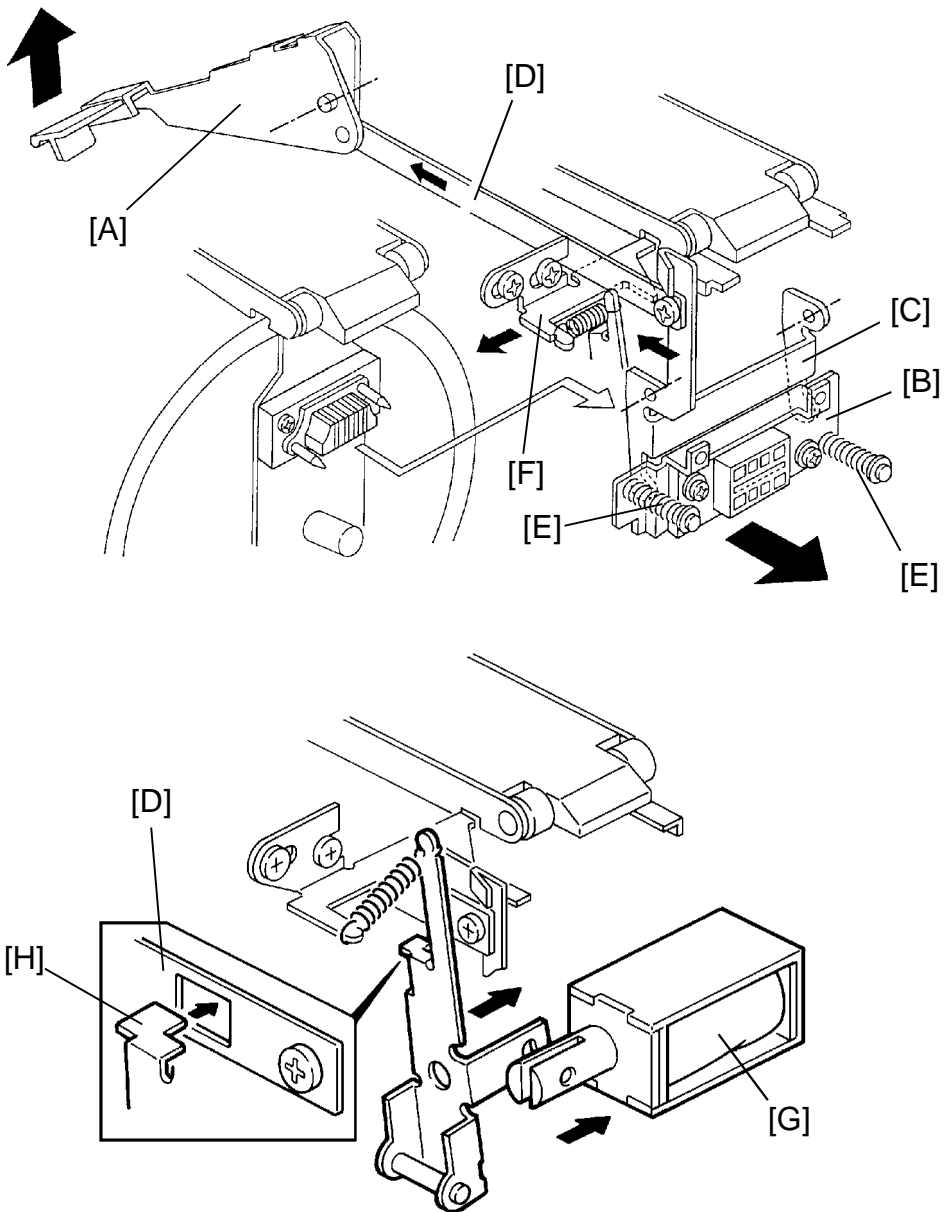

When the drum release lever [A] in front of the machine is raised, the connector [B] is pushed away from the drum by the bracket [C] through the link [D] to be disconnected. The connector moves only horizontally due to the guidance of the shafts [E]. The bracket [C] also pushes the drum lock lever [F] to release the drum lock allowing the drum to be removed. While the drum is out of home position, the drum lock solenoid [G] is energized and the stopper [H] locks the link [D] not to be pulled. The solenoid is de-energized when the drum stops at the home position (1st drum home position sensor is actuated).

2.2 CIRCUIT

Detailed Descriptions

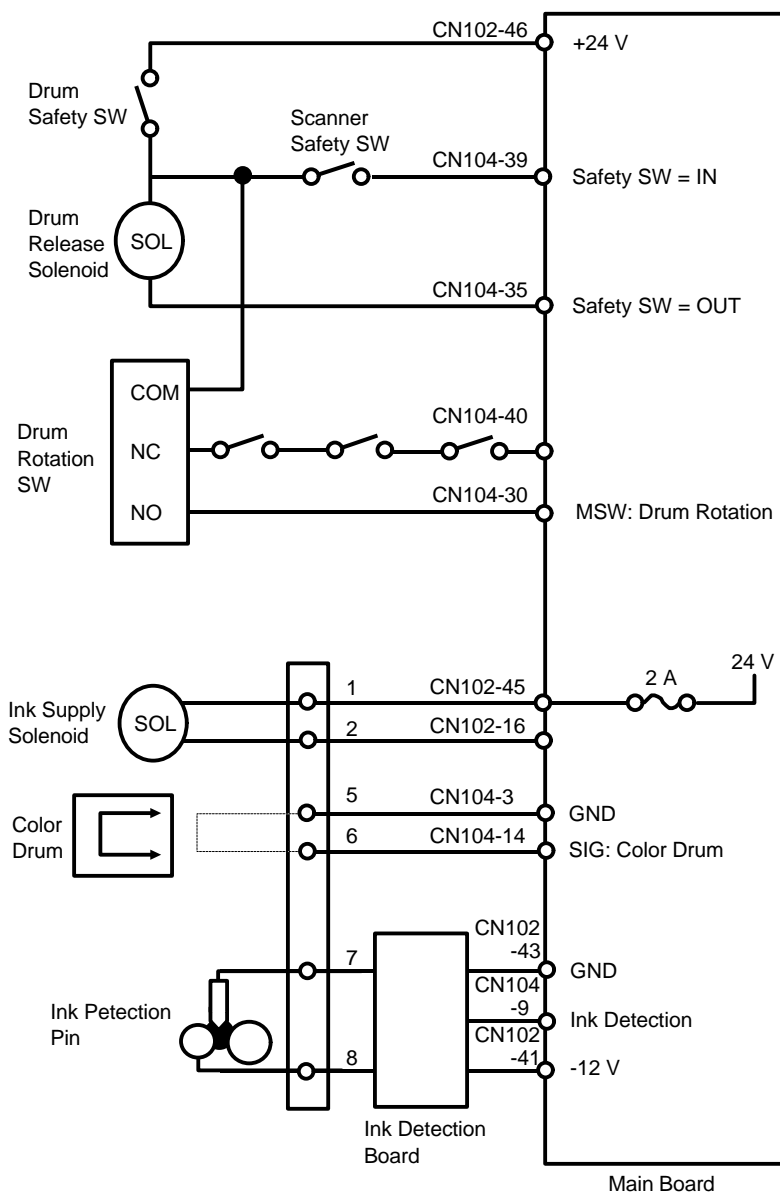

Component Name	I/O	ID Conversion Board		Description
		CN No		
MSW: Drum Rotation	I	104-30	0V → 24V	When the drum rotation SW is pressed, CN104-30 goes to 24V.
Ink Supply SOL	O	102-16	24V → 0V	When the solenoid is turned on, CN102-16 goes to 0V.
Drum Release SOL	O	104-35	24V → 0V	When the drum position sensor 1 is deactuated, CN104-35 goes to 0V.
Ink Detection PCB	I	104-9	12V → 0V	When there is no ink on the ink roller, CN104-9 goes to 0V.

3. PAPER DELIVERY

3.1 EXIT PAWL AIR PUMP MECHANISM

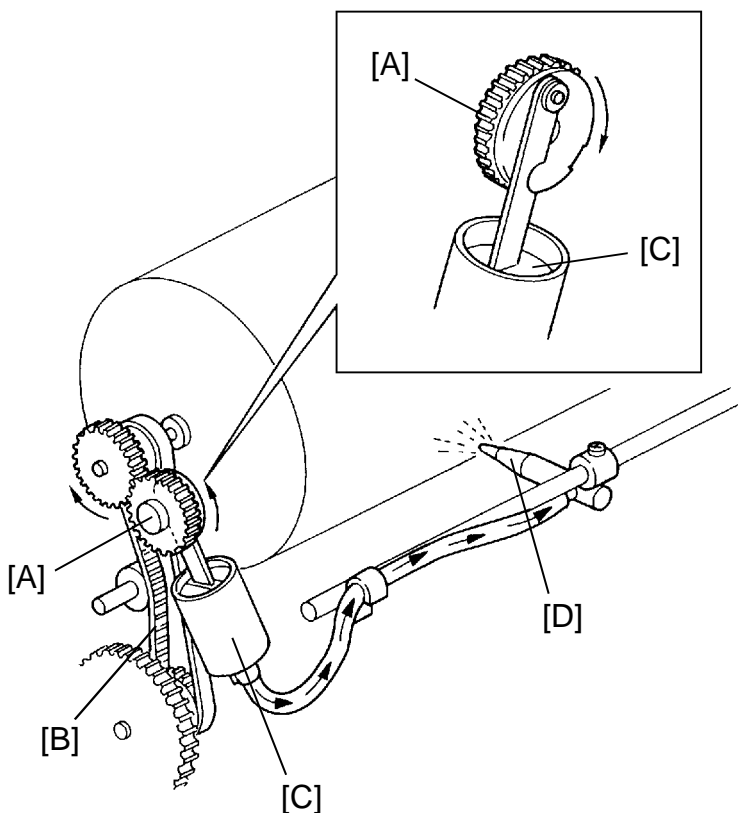

The main motor drive is transmitted to the pump gear [A] through gears and a timing belt [B]. The gear [A] rotates and drives the piston [C] back and forth.

The piston moves forward and pushes a jet of air out through the nozzle [D]. This jet of air helps separating the paper from the drum.

SECTION 3

INSTALLATION

1. INSTALLATION PROCEDURE

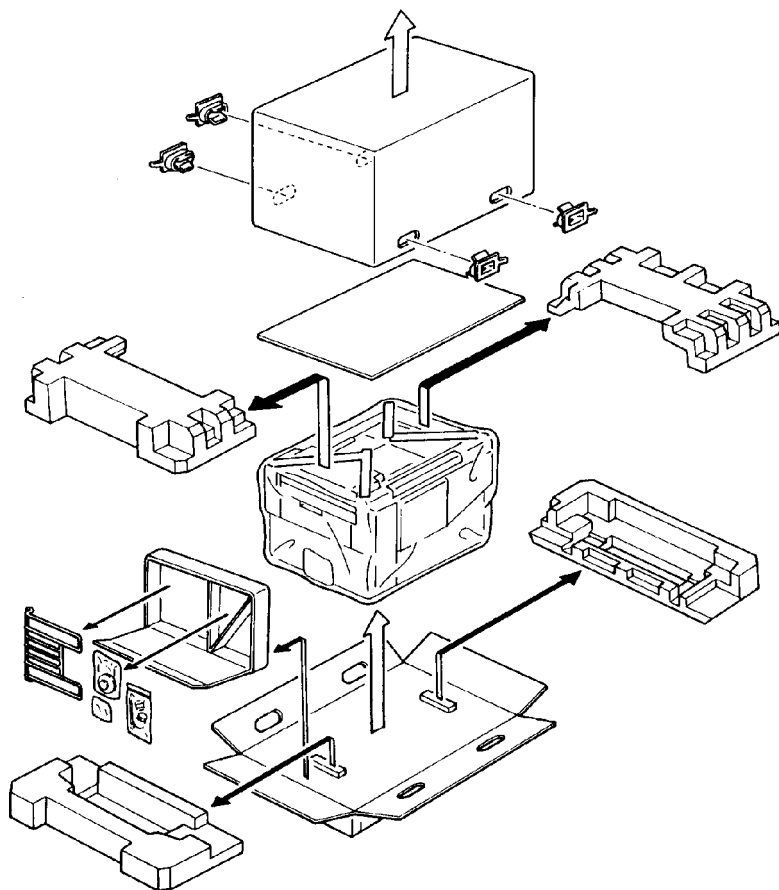

Installation

1. Make sure that you have all the accessories listed below.

(1) Original Exit Tray	1
(2) Right Tray Bracket	1
Left Tray Bracket.....	1
(3) Fixing Screws	2
(4) Master Spools	2
(5) Thermal Head Cleaner	1
(6) Operating Instructions (USA and Asia version only).....	1
(7) NECR	1
(8) Installation Procedure (English)	1

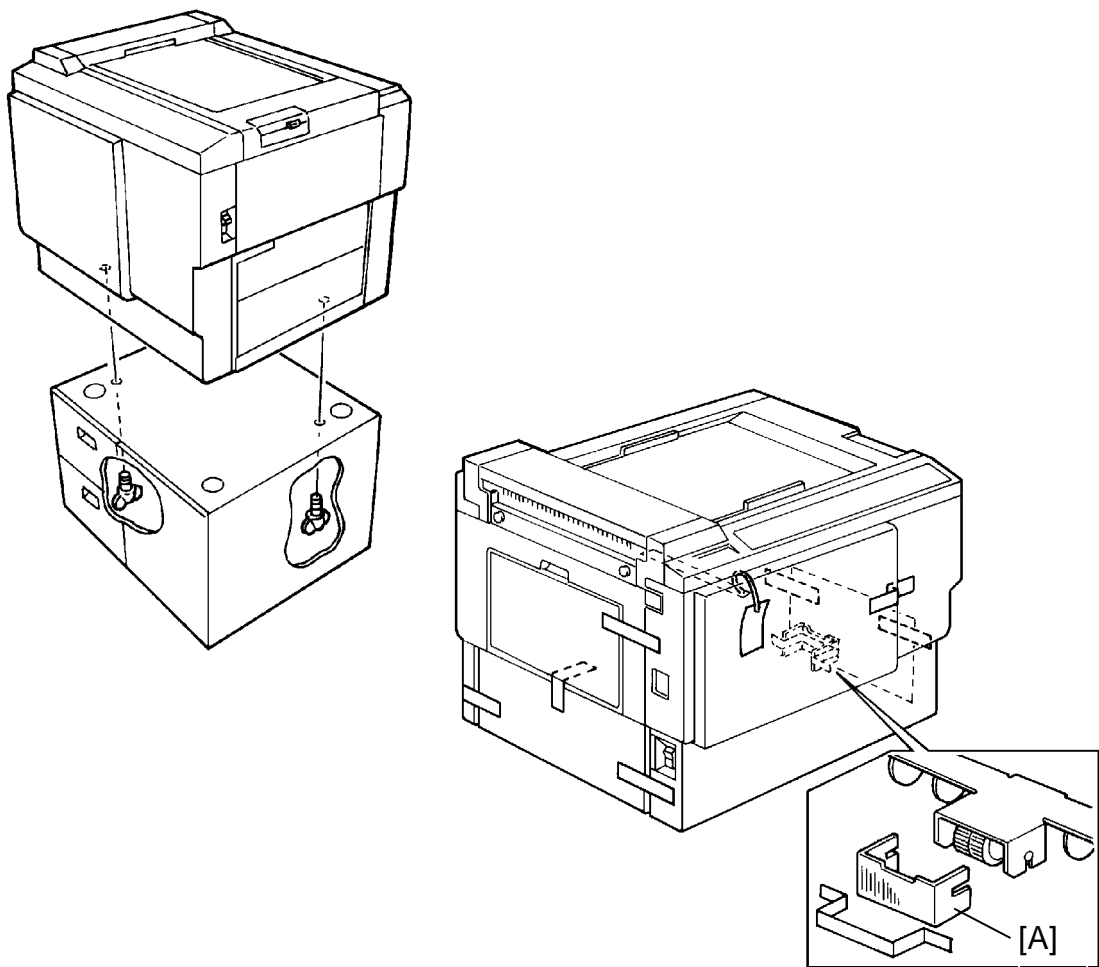

2. Mount the machine on the optional table (2 screws packed with table).
3. Remove the tape and string securing the covers and units as shown on the right.
 - a. Open the paper feed tray. Then remove the cushion plate [A] from the paper feed roller section.
 - b. Open the master delivery unit. Then remove the tape securing the paper delivery guide plate.

4. Remove the protective sheet [A] from the drum unit.

a. Open the front door.

b. Take out the drum unit.

c. Remove the protective sheet from the master clamper.

d. Reinstall the drum unit in the machine.

e. Push down the drum lock lever [B].

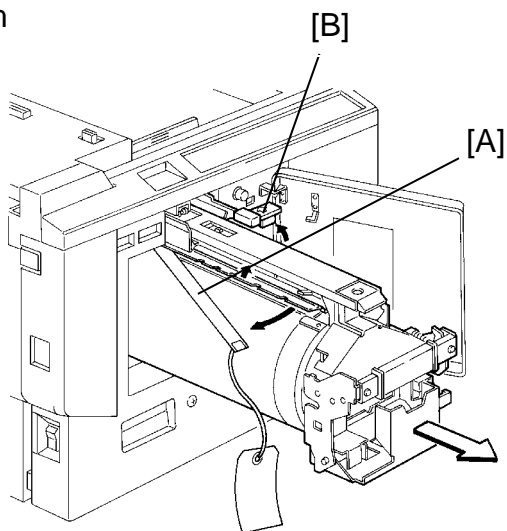

Installation

5. Install the original exit tray [B].

a. Hook the right and left tray brackets on the stepped screws.

b. Set the original exit tray on the brackets.

c. Secure the brackets with fixing screws.

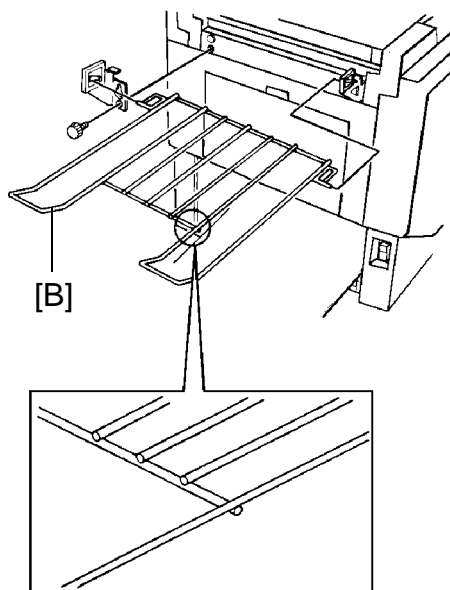

6. Loading Paper on the Paper Feed Table

- Open the paper feed table.
- Stack the paper neatly on the paper feed table.
- Position the paper feed side plates so that they lightly contact the paper on both sides.
- Position the paper delivery table for the printing paper size, using the scale on the table.
- Position the paper delivery side plate for the printing paper size, using the scale on the table.

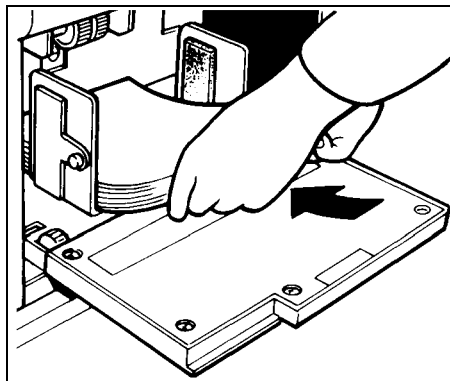

7. Installing the Master Roll (Type VT-II-M)

- While lifting the release lever, slide the scanner unit to the left.
- Attach a spool to each end of the master roll.
- Set the master roll in the machine.
NOTE: The vinyl side faces down.
- Return the pressure release lever to the original position.
- Plug in the power cord and turn on the main switch.
- Press the Master Cut button.
- Remove the cut master paper.
NOTE: Confirm that the master paper is not bent or creased.
- Close the scanner unit.

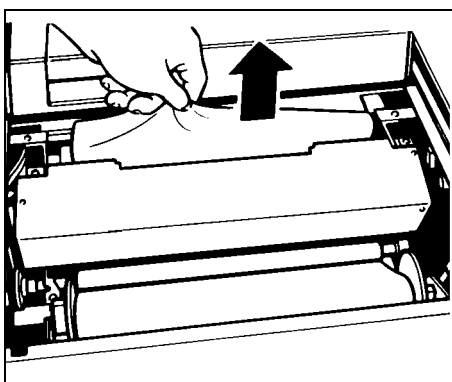
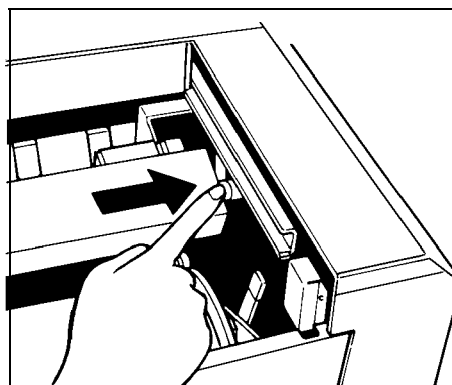
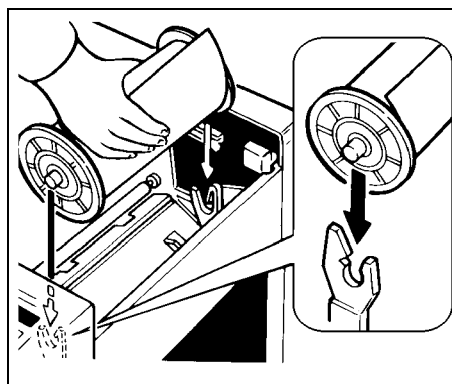

8. Installing the Ink Cartridge

- Open the front door and lower the ink holder.
- Remove the ink cartridge cap.
- Insert the ink cartridge into the ink holder and return the ink holder to the original position.
- Close the front door.

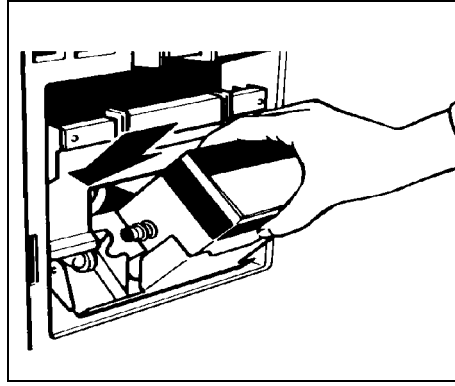

9. Idling

- While holding down the "0" key on the operation panel, press the Reset key.
- If  + **D** blinks on the operation panel, repeat the above procedure.

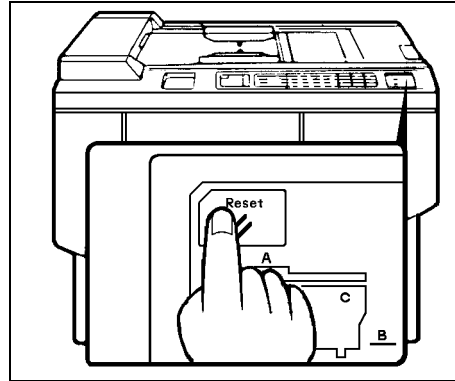

Installation

10. Test Printing

- Adjust the original guide to match the original size.
- Set the original face down.
- Input the desired number of prints with the number keys and press the Master Making key.

NOTE: With a new machine, the master paper misfeed indicator  + **F** blinks because there is no master yet on the drum. Press the Reset key, then press the Master Making key.

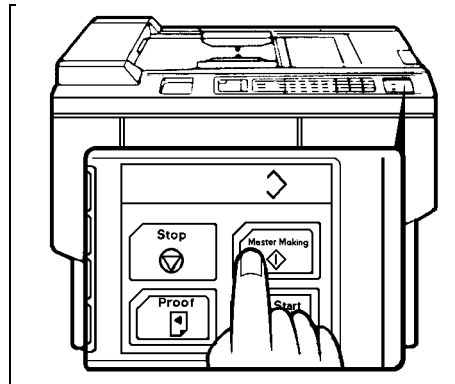

- After one sheet of paper is delivered, make prints at the lowest print speed (1) until the print image density stabilizes. Use a test chart to check for changes in the image density.
- Check the copy image after about one hundred prints.

SECTION 4

SERVICE TABLES

1. MAINTENANCE TABLE

The following VT2105 tables are identical to those from the VT2000 series.

- Lubrication Points
- User's Maintenance
- Table of Periodic Inspection

1.1 TABLE OF SERVICE CALL INDICATIONS

Indication	Trouble	Possible causes
E 01	Malfunction in cutter section: The cutter does not reach both right and left cutter position switches within 2 seconds. 	1) Drive wire cut 2) Drive section malfunction 3) No power supply
E 02	Malfunction in the paper table drive section: The lower limit sensor or the paper table height sensor status does not change even though the paper table UP or Down signal is applied.	1) Drive worm gear broken 2) Mounting screw of the worm gear broken 3) No power supply
E 03	Malfunction in the program.	1) Defective PROM 2) Defective control PCB
E 04	Temperature of the thermal head or the power supply unit is high: Temperature of the thermal head becomes greater than 57°C or the temperature of the power supply unit becomes greater than 85°C when the machine is in stand-by condition.	1) Defective thermistor 2) Defective thermal head 3) Defective power supply unit
E 05	Malfunction in the image shifting section:	1) Encoder connector of the image shifting section is connected. 2) Defective encoder
E 06	Mechanical lock: Drum rotation sensor detects that the drum rotation speed is abnormal.	1) Mechanical lock 2) Main motor failure
E 07	Malfunction in the program (PROM). When using I/O check mode, "E 07" lights up if the ROM is defective. NOTE: When "E 03" is lit, access I/O check mode to check if the PROM is defective.	Defective ROM
E 08	Thermal head drive signal (ENL) is defective.	Defective image processing board.

2. DIP SW, LED, VR, AND TP TABLES

2.1 DIP SW TABLE (ON THE MAIN BOARD)

No.	DIP SW	Function	Remarks
1	DP102-1	Cover Open	Turn on to disable all cover safety switch functions except ADF cover safety. (Normal: OFF)
2	DP102-2	ADF Cover Open	Turn on to disable the ADF cover safety switch function. (Normal: OFF)
3	DP101-1	Key Counter	Turn on when installing the key counter. (Normal: OFF)
4	DP101-2	Buzzer ON/OFF	Turn on to sound the beeper. (Normal: OFF)
5	DP101-3	Initial Print	ON: Makes two prints after making a master. OFF: Makes one print after making a master. (Normal: OFF)
6	DP101-4	ADF Operation	Turn on to kill the ADF function. (Normal: OFF)
7	DP101-5	Class/Memory Selection	To select class or memory function. OFF: Class, ON: Memory. (Normal: ON)
8	DP101-6	I/O Check Procedure	Selects the I/O check mode access procedure. (ON: Europe/Asia version, OFF: US version)
9	DP101-7	Erase White Line	Turn on to erase the white line 60 mm from the leading edge. (NOTE1) (Normal: OFF)
10	DP101-8	Double Master Compression	If this switch is ON, when the master making key is pressed, masters in the master eject box are compressed once before plotting starts and detects if the master box is full. (NOTE2) (Normal: OFF)
11	DP103-1	Reduction Ratio Compensation	Used to adjust the reduction ratio in the sub-scan direction.
12	DP103-2	Reduction Ratio Compensation	Used to adjust the reduction ratio in the sub-scan direction.
13	DP103-3	Reduction Ratio Compensation	Used to adjust the reduction ratio in the sub-scan direction.
14	DP103-4	Mode Clear	If this switch is turned on, the blind key on the operation panel is used as the clear mode key. (Normal: OFF)
15	DP103-5 DP103-6	Skip Paper Feed Setting	Setting these switches enables skip paper feed mode. After setting these switches, the blind key is used to access skip paper feed mode. (NOTE3) (Normal: 103-5 OFF, 103-6 OFF)

NOTE1 The shock wave from clamping might make a thin white line 60 mm from the leading edge. This line is visible when the image is made by photo mode. By turning on DPS 101-7, the reverse roller solenoid ON timing is delayed to absorb the shock wave. However, the above measure sometimes disturbs master registration (image position on the master).

NOTE2 If the customer does not dispose of the ejected masters even though full master is indicated (Turning off the main switch resets full master condition), master eject jams or master eject belt might slip off. Double master compression prevents the customer from making a master when the master box is full. However, if this switch is turned on, the master compression is performed twice for every master made. This hastens parts wear and may cause trouble.

NOTE3 The following skip number can be selected by setting DIP SW 103-5 and 103-6.

DPS103	1 Sheet/ 1 Rotation	1 Sheet/ 3 Rotation	1 Sheet/ 5 Rotation	1 Sheet/ 8 Rotation
5	OFF	ON	OFF	ON
6	OFF	OFF	ON	ON

If both DPS 103-4 (Mode Clear) and DPS 103-4/5 (Skip Paper Feed Setting) are selected, Mode Clear mode is selected. (Skip Feed is ignored.)

2.2 DIP SW TABLE (Image Processing Board)

No.	DIP SW	Function	Remarks
1	DPS 400-1	Test Pattern	Turn off to access test pattern mode (Normal: ON)
2	DPS 400-1	Dither Pattern	Used to change dither matrix (ON: 4 x 4, OFF: 6 x 6)

2.3 LED TABLE

No.	LED	Function	Remarks
1	LED 101	Main Motor ON	When the main motor turns on, LED lights
2	LED 102	1st Paper Exit SN Detection	When paper is detected, LED lights
3	LED 103	2nd Paper Exit SN Detection	When paper is detected, LED light
4	LED 104	Ink Detection	When ink is detected, LED lights NOTE: When the drum release lever is raised, the drum connector is disconnected and LED turns off.

2.4 VR TABLE (Main Board)

No.	VR	Function
1	VR 101	Main motor speed adjustment
2	VR 102	1st paper exit sensor adjustment
3	VR 103	2nd paper exit sensor adjustment

2.5 VR TABLE (AD Conversion Board)

No.	VR	Function
1	VR 600	White level adjustment
2	VR 601	Black level adjustment

2.6 TEST PIN TABLE (Main Board)

No.	Test Pin	Function	Standard Voltage
1	TP 101	GND	0 V.
2	TP 102	1st paper exit sensor (PDLV)	ON: 5~10 V OFF: 0 V
3	TP 103	1st paper exit sensor (PROL)	ON: 5V OFF: 0 V

2.7 TEST PIN TABLE (A/D Conversion Board)

No.	Test Pin	Function
1	TP 600	GND
2	TP 601	Shift signal output (SH)
3	TP 602	CCD output (OS)
4	TP 603	Inverted and amplified CCD output
5	TP 604	Black level standard voltage output

3. SERVICE PROGRAM TABLE: VT2105

3.1 HOW TO ACCESS I/O CHECK MODE

1. A4 version:

Turn on the main switch while holding down the Print Start key, Stop key, Clear key and Full Master Detection switch.

LT version:

Turn on the main switch while holding down the Print Start key, Stop key, and Clear key.

2. Press the Memory/Class key to select either "Input" or "Output".

Memory indicator "1" Input

Memory Indicator "0" Output

3.2 OUTPUT MODE:

COUNTER INDICATION	OUTPUT
0001-0	Turns on the drum (10 rpm).
0002-0	Turns on the drum (30 rpm).
0003-0	Turns on the drum (75 rpm).
0004-0	Turns on the paper table drive motor (up).
0005-0	Turns on the paper table drive motor (down).
0006-0	Turns on the vacuum motor.
0007-0	Turns on the master eject solenoid.
0008-0	Turns on the master eject clamper opening solenoid.
0009-0	Turns on the master feed clamper opening solenoid.
0010-0	Turns on the reverse roller solenoid.
0011-0	Turns on the paper feed solenoid and the printing pressure solenoid.
0012-0	Turns on the ink supply solenoid.
0013-0	Turns on the original transport motor.
0014-0	Turns on the master feed motor.
0015-0	Turns on the fluorescent lamp.
0016-0	Master Process Command (photo LED ON)
0017-0	Reverses the master eject motor (turn the eject rollers).
0018-0	Turns on the master eject motor (pressure plate up/down).
0019-0	Turns on the cutter motor (moves it from front to rear).
0020-0	Turns on the cutter motor (moves it from rear to front).
0021-0	Turns the image shifting motor in the (+) direction.
0022-0	Turns the image shifting motor in the (-) direction.
0023-0	Turns on the magnetic counter for paper.
0024-0	Turns on the magnetic counter for master.
0025-0	Turns on the drum reverse rotation relay.
0026-0	Magnification ratio : 100% (LED ON)
0027-0	Magnification ratio : 93% (LED ON)
0028-0	Magnification ratio : 82% (A4 version)/ 75% (LT version) (LED ON)
0029-0	Magnification ratio : 71% (A4 version)/ 64% (LT version) (LED ON)
0030-0	Turns on the drum (10 rpm), the paper feed solenoid, and the printing pressure solenoid.
0031-0	Tape marker (option) feeds out strips of paper.
0032-0	Turns on the ADF drive motor (Not used).
0033-0	Turns on the ADF original pressure solenoid (not used).
0034-0	Turns on the drum lock solenoid.
0035-0	Outputs the thermal head voltage (VHS).
0036-0	Simulates original transportation in ADF mode. (Fluorescent lamp and CCD do not work.)

NOTE: 0001-0 to 0006-0 and 0030-0 are not activated when the safety cover is open.

3.3 INPUT MODE:

COUNTER INDICATION	INPUT	
0001-1	SW: Master Eject Detection	(Indicator lights when sensor ON)
0002-1	SW: Pressure Plate Position	(Indicator lights when switch ON)
0003-1	SN: 2nd Original Detection	(Indicator lights when sensor ON)
0004-1	SN: Original Registration Detection	(Indicator lights when sensor ON)
0005-1	SN: 1st Drum Position Detection	(Indicator lights when sensor ON)
0006-1	SN: 2nd Drum Position Detection	(Indicator lights when sensor ON)
0007-1	SN: Master Detection	(Indicator lights when master is set)
0008-1	SN: Master Buckle Detection	(Indicator lights when master appears)
0009-1	SW: Left Cutter	(Indicator lights when switch ON)
0010-1	SW: Right Cutter	(Indicator lights when switch ON)
0011-1	SW: Master Eject Box	(Indicator lights when switch ON)
0012-1	SW: Full Master Detection	(Indicator lights when switch ON)
0013-1	SN: Paper End	(Indicator lights when paper is set)
0014-1	SN: Paper Table Low Limit	(Indicator lights when sensor ON)
0015-1	SN: Paper Table Height	(Indicator lights when sensor ON)
0016-1	SN: Pressure	(Indicator lights when sensor ON)
0017-1	SN: 1st Paper Exit (LED103)	(Indicator lights when paper is present)
0018-1	SN: 2nd Paper Exit (LED102)	(Indicator lights when paper is present)
0019-1	SW: Cover Safety/Drum Detection	(Indicator lights when switch ON)
0020-1	SN: Color Drum	(Indicator lights when color drum is set)
0021-1	DIP SW-1 (DIP101-1)	(Indicator lights when switch ON)
0022-1	DIP SW-2 (DIP101-2)	(Indicator lights when switch ON)
0023-1	DIP SW-3 (DIP101-3)	(Indicator lights when switch ON)
0024-1	DIP SW-4 (DIP101-4)	(Indicator lights when switch ON)
0025-1	Not Used	
0026-1	SN: Ink Detection	(Indicator lights when ink appears)
0027-1	SN: Thermistor	(Indicator lights when temp. is standard)
0028-1	Key: Proof	(Indicator lights when key ON)
0029-1	Key: Image Shift +	(Indicator lights when key ON)
0030-1	Key: Image Shift -	(Indicator lights when key ON)
0031-1	SW: Drum Rotation	(Indicator lights when switch ON)
0032-1	SW: Master Manual Cut	(Indicator lights when switch ON)
0033-1	SN: 1st Original Detection	(Indicator lights when sensor ON)

4. TEST PATTERN IMAGE MODE

The purpose of this mode is to distinguish whether the cause of the image problem is located before or after image processing.

Output image: The normal output of this test pattern image mode is one of the dither matrix pattern as illustrated below.

Master processing length:

Main scan (Horizontal) direction: Full width of the thermal head

Sub-scan (Vertical) direction: Same as the vertical size of the original set on the original table.

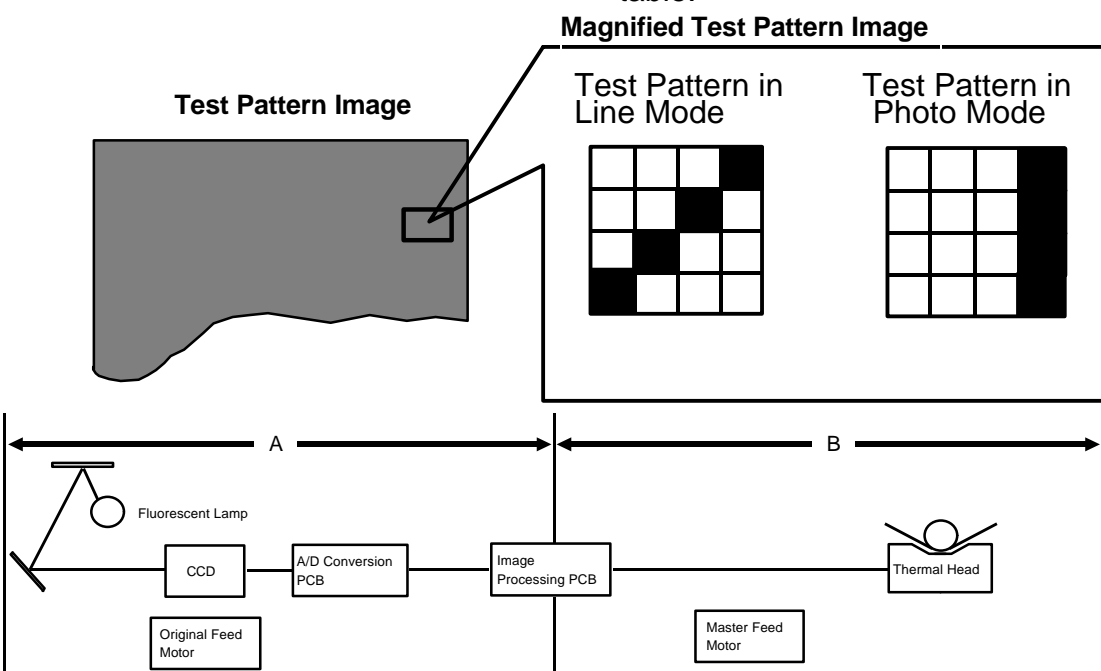

This test pattern is generated by the image processing PCB.

[Example] Problem:

Possible Cause 1

Vertical white lines appear on the print.

If the same problem appears on the output image from the thermal head in test pattern image mode, the cause should be in area B, as shown above.

Possible Cause 2

If the output image from the thermal head is correct in test pattern mode but the output image in the normal mode is incorrect, the cause should be in area A, as shown above.

4.1 OPERATION: (To Enter Test Pattern Image Mode)

- 1) Remove the front cover.
- 2) Turn off DIP SW 400-1 on the image processing PCB only when the power switch is off.
- 3) Turn on the main switch.
- 4) Press the Image Mode key to select the test pattern image.

Test pattern in line mode

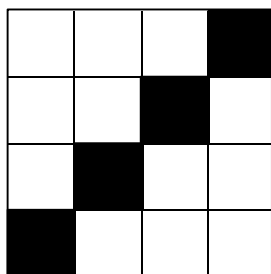

Test pattern in photo mode

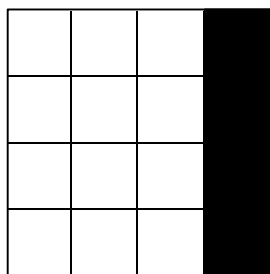

- 5) Set the original on the original table.

CAUTION: To prevent overheating of the thermal head, make the original as short as possible. Any type of original is suitable as the test pattern being used is in the image processing PCB memory.

Service
Tables

- 6) Press the Master Making key and make prints.
- 7) After completion of the test pattern image mode, turn on DIP SW 400-1.

5. AVAILABLE OPTION/SUPPLY TABLE

- O: Standard combination
 Δ: Usable under certain conditions
 X: Cannot be used

		VT2105
Masters	Type 800	X
	Type 900	X
	VT-S	X
	VT-M	X *NOTE1
	VT-L	X
	VT-II-M	O
Inks	Black	O
	Color (rd/bl/gn/br)	O
	VT-Black-800	X
Color Drums	Color Drum	Δ *NOTE2
	Color Drum Type 905	Δ *NOTE2
	Color Drum VT2000-M	O
	Color Drum VT2000-LG	X *NOTE3
	Color Drum VT2000-S	X *NOTE3
	Color Drum VT3000-L	X
	Color Drum VT3000-S	X
Others	Cassette B4	X
	Cassette VT3000-L	X
	Cassette VT3000-S	X
	Tape Marker Type 20	O
	Priport Table	O
	Priport Table VT3000	X

NOTES: 1. The VT-M master can be installed on the VT2105, however, a weak image (sometimes image blank) will appear. This is because the VT-II-M master is more sensitive than the VT-M master.

2. The modified master clamber (P/N C2074948) must be installed.
3. The drum can be installed, however, the maximum image area is limited according to the drum screen size.

SECTION 5

REPLACEMENT AND ADJUSTMENT

- 1) The replacement and adjustment procedures not mentioned in the following pages are identical to those of the VT2000 series.
- 2) The purpose and procedure of the following adjustments are identical to those of the VT2000 series, however the adjusting value or VR is different.

• PRINTING PRESSURE ADJUSTMENT

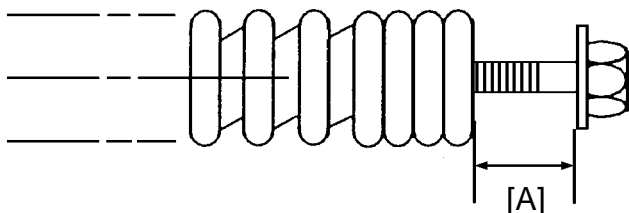

Adjust the clearance [A] to be 14 ± 0.5 mm by turning the adjusting belt [B].

• PRINTING SPEED ADJUSTMENT

Adjust the drum speed by turning VR101 on the main board.

• EXIT PAWL CLEARANCE ADJUSTMENT

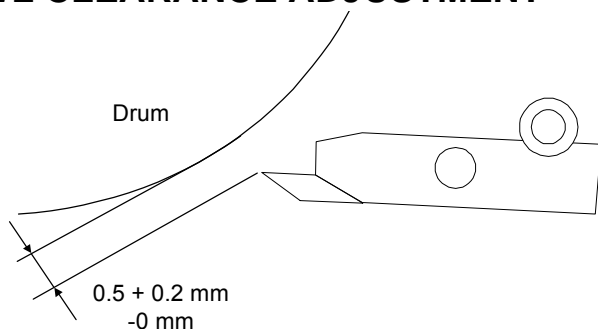

Adjust the exit pawl clearance so that the distance between the exit pawl and the drum is between 0.5 and 0.7 mm.

• FIRST PAPER EXIT SENSOR ADJUSTMENT

Adjust the 1st paper exit sensor sensitivity by turning VR103. Check the sensor status with LED103.

• SECOND PAPER EXIT SENSOR ADJUSTMENT

Adjust the 2nd paper exit sensor sensitivity by turning VR102. Check the sensor status with LED102.

1. OPTICS ADJUSTMENT

The method of the optics adjustment is the same as the VT2000 series. However, the wave shape is not exactly same because the pixel density of VT2105 is different from that of the VT2000 series.

Necessary Tools

- 1) Facsimile Text Chart R-21 (99992131)
- 2) Resolution Chart (A0129110)
- 3) Oscilloscope

1.1 PREPARATION FOR ADJUSTMENT

1. Remove the original table and the original table cover.
2. Connect the terminals of the oscilloscope to the following test pins on the A/D conversion board.

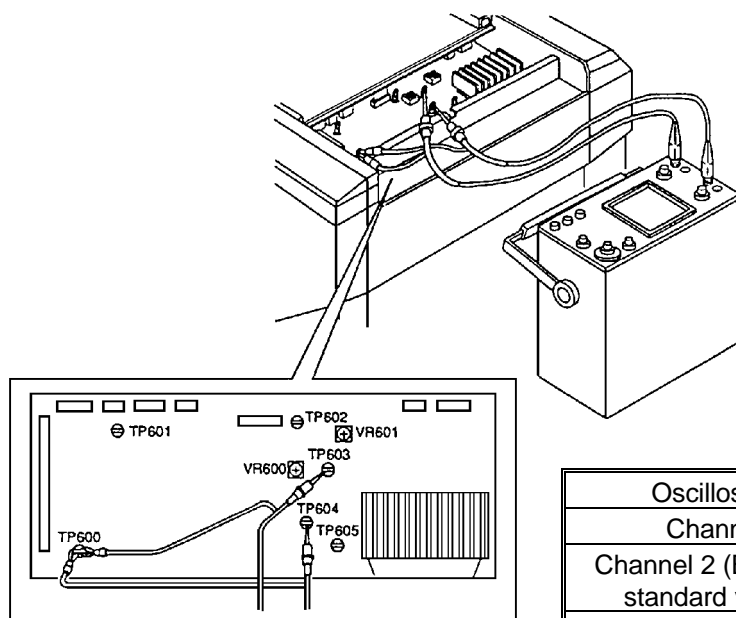

3. Access "I/O Check Mode".

- Turn on the main switch while holding the Print Start key, Stop key and Clear key on the operation panel. ----- LT version
- Turn on the main switch while holding the Print Start key, Stop key, Clear key and the full master detection switch. ----- A4 version

4. Set "15" in the copy counter using the number keys, and set "0" in the memory/class display by pressing the memory/class key
5. Press the Print Start key to turn on the fluorescent lamp.

1.2 BLACK LEVEL ADJUSTMENT

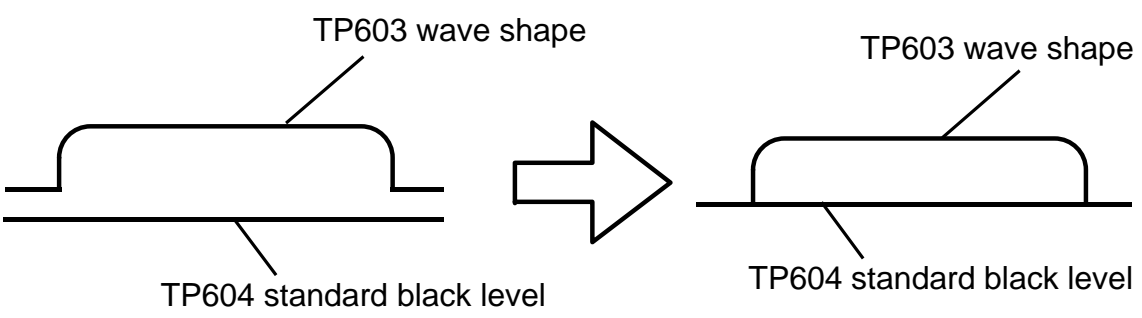

Adjust VR601 so that the black level at TP603 is the same as the standard black level ($1.4 V \pm 0.03 V$).

1.3 SHADING ADJUSTMENT

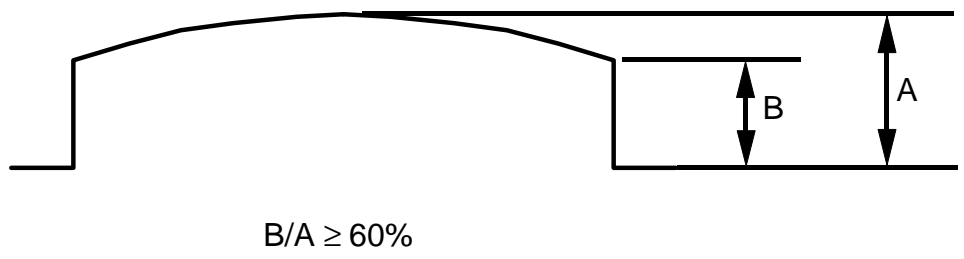

Replacement Adjustment

Adjust the shading plate position so that the wave is shaped as shown above.

1.4 SCAN LINE POSITION ADJUSTMENT

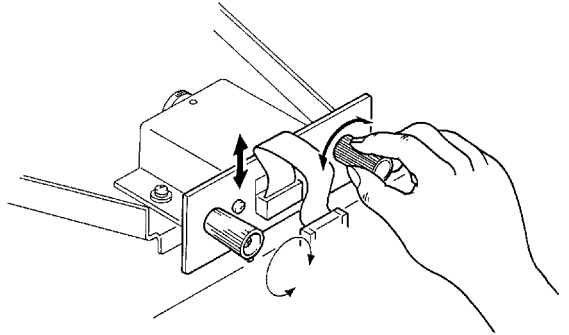
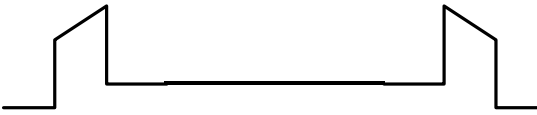

Set the test chart R-21 so that the 1 mm black line is positioned 16 mm away from the edge of the lower original guide plate.

Adjust the CCD board position so that the shape of the wave is similar to the above illustration.

1.5 READING START POSITION ADJUSTMENT (In The Main Scan Direction)

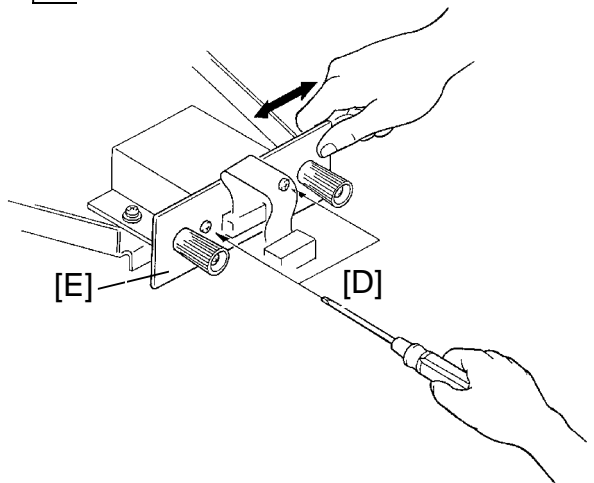

Set the test chart so that the center line, located at the leading edge of the test chart, is positioned above the original leading edge sensor actuator. Then feed the test chart so that the center line can be read.

Adjust the CCD board position so that the above wave is displayed.

1.6 FOCUS ADJUSTMENT

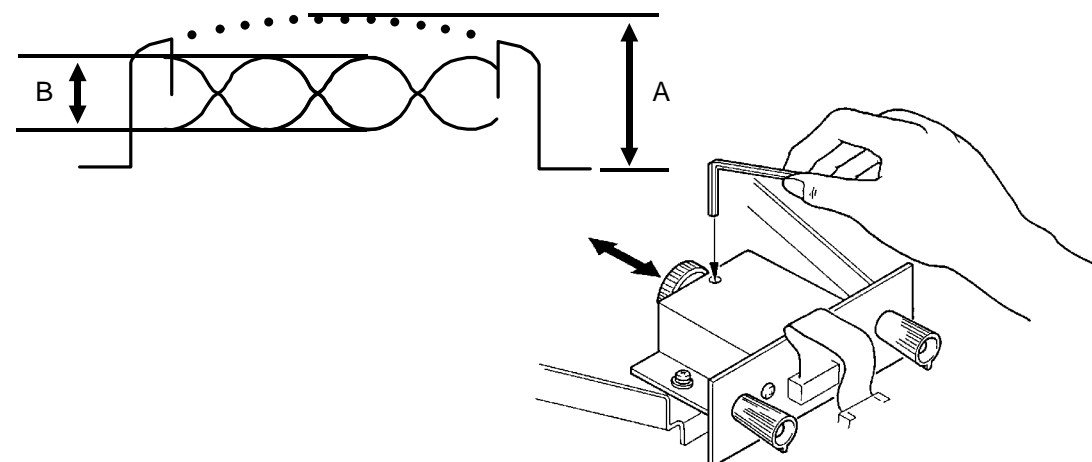

- $\frac{B}{A} \times 100 \geq 20\%$
- Amplitude "B" (difference between white and black levels) must be a maximum.

Position the resolution chart so that the 300 DPI section can be read. Adjust the lens position so that the above wave appears.

1.7 REDUCTION RATIO ADJUSTMENT

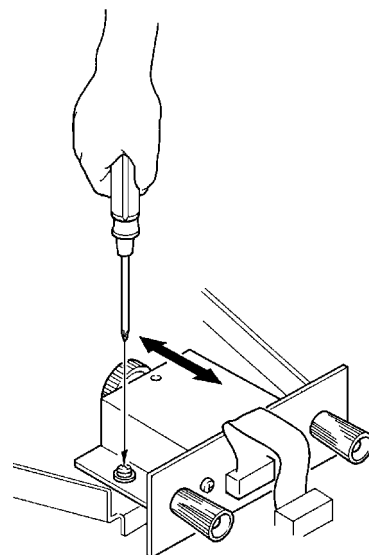
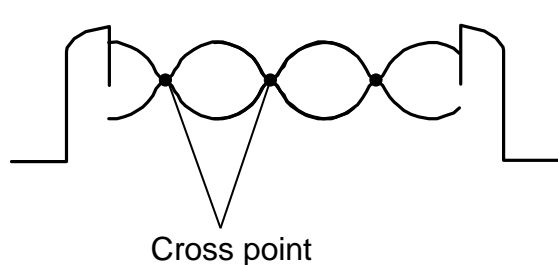

Replacement
Adjustment

Position the resolution chart so that the 300 DPI section can be read. Adjust the lens block position so that the cross points are less than 8.

1.8 WHITE LEVEL ADJUSTMENT

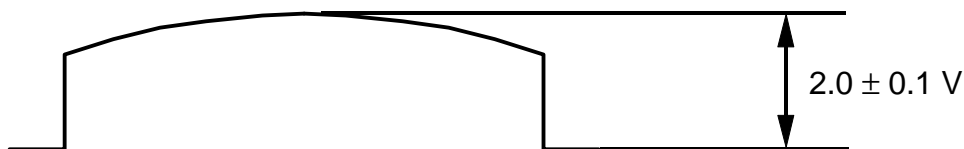

Adjust the VR600 on the AD conversion board so that the maximum level is 2.0 ± 0.1 V.

1.9 IMAGE MAGNIFICATION IN THE SUB-SCAN DIRECTION ADJUSTMENT

Adjust the magnification ratio in the sub-scan direction using DIP103-1, 2, 3 on the main board, so that the printed image length is $100\% \pm 0.5\%$ by comparing the original image length.

–DIP SW/Correction Ratio–

DPS 103			$\frac{\text{Original Length}}{\text{Print Image Length}} \times 100$
1	2	3	
OFF	OFF	OFF	100%
OFF	ON	OFF	99.25%
OFF	OFF	ON	98.75%
OFF	ON	ON	98.25%
ON	OFF	OFF	100%
ON	ON	OFF	100.75%
ON	OFF	ON	101.25%
ON	ON	ON	101.75%

2. THERMAL HEAD VOLTAGE ADJUSTMENT

Purpose: To maintain master making quality and extend the lifetime of the thermal head.

NOTE: This adjustment is always required when the thermal head or power supply board is replaced.

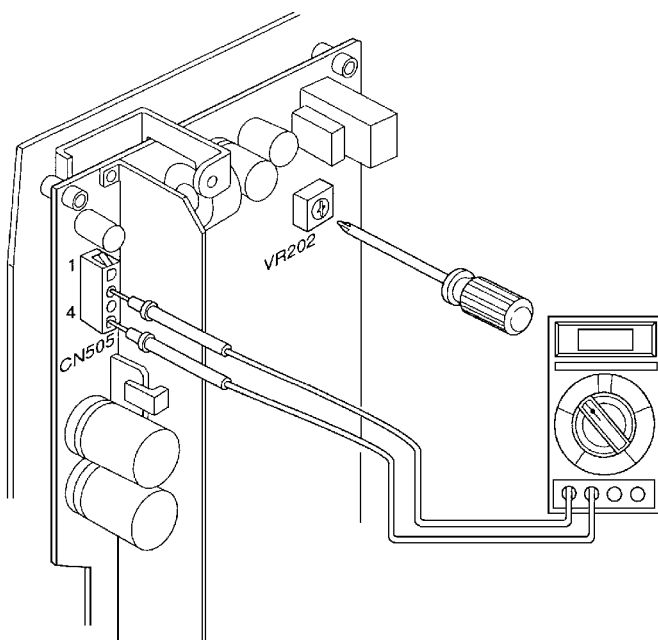

1. Remove the rear cover of the machine.
2. Check the voltage noted on the decal, located on the thermal head.
(The voltage varies according to each thermal head.)
3. Access "I/ Check Mode".
 - Turn on the main switch while holding the Print Start, Stop and Clear keys. ----- LT version
 - Turn on the main switch while holding the Print Start, Stop, Clear keys and the full master detection switch. ----- A4 version
4. Input 35 in the copy counter using the number keys, and set "0" in the Memory/Class display by pressing the Memory/Class key.
5. Press the Print Start key to apply the thermal head voltage.
6. While holding down the Print Start key, confirm that the voltage between pins 2(VHD) and 4(GMD) on CN505 is at the level specified on the decal (Within + 0 V , - 0.1 V).
7. If it is not, adjust VR202 on the power supply board.

3. AIR PUMP TIMING ADJUSTMENT

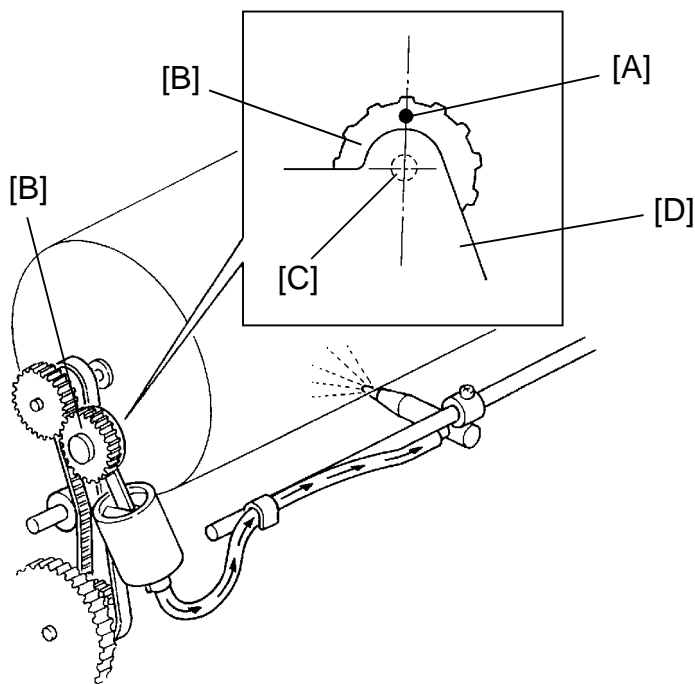

Purpose: To ensure that the paper exit pawl air pump produces a jet of air at the proper timing

1. Remove the rear cover.
2. Set the drum in the home position.
3. Confirm that the mark [A] on the pump drive gear [B] is right over the gear shaft [C].
4. If incorrect, remove the support plate [D] (5 screws) and reposition the gear.
5. Rotate the drum to the home position and confirm step 3 again.